

SN75240 DUAL UNIVERSAL SERIAL BUS PORT TRANSIENT SUPPRESSOR

SLLS266A – FEBRUARY 1997 – REVISED MAY 1998

- Design to Protect Submicron 3-V or 5-V Silicon from Noise Transients
- Applicable to Two High- or Low-Speed Universal Serial Bus (USB) Host, Hub or Peripheral Ports
- Port ESD Protection Capability Exceeds:
 - 15-kV Human Body Model
 - 2-kV Machine Model
 - 8-kV IEC1000-4-2†
- Low Current Leakage . . . 1 μ A Max
- Stand-Off Voltage . . . 6.0 V Min
- Low Capacitance . . . 35 pF Typ

description

The SN75240 is four transient voltage suppressors designed to provide additional electrical noise transient protection to two USB ports. Any cabled I/O can be subjected to electrical noise transients from various sources. These noise transients can cause damage to the USB transceiver and/or the USB ASIC if they are of sufficient magnitude and duration. The USB ports are typically implemented in 3-V or 5-V digital CMOS with very limited ESD protection. The SN75240 can significantly increase the port ESD protection level and reduce the risk of damage to the large and expensive circuits of the USB port.

IEC1000-4-2 Compliance Test Levels

IEC1000-4-2 COMPLIANCE LEVEL	MAXIMUM TEST VOLTAGE	
	CONTACT DISCHARGE (kV)	AIR DISCHARGE (kV)
1	2	2
2	4	4
3	6	8
4	8	15



Please be aware that an important notice concerning availability, standard warranty, and use in critical applications of Texas Instruments semiconductor products and disclaimers thereto appears at the end of this data sheet.

† IEC1000-4-2 ESD performance is measured at the systems level and system designs influence the results of these tests. Testing done at the component level act as an indicator that the system passes at a particular compliance level, but does not ensure that the system passes at that level. The Texas Instruments USB EVM with the TUSB2040 USB controller (2-kV HBM and 200-V MM) was used for the test platform.

P OR PW PACKAGE
(TOP VIEW)



schematic

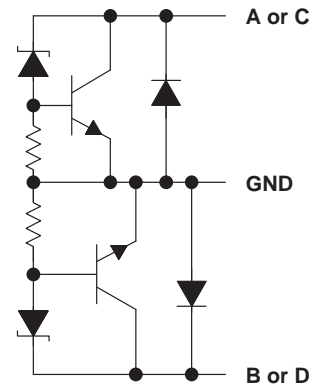

(One Suppressor Shown)

NOTE A: All four GND terminals should be connected to ground.

CURRENT
vs
VOLTAGE

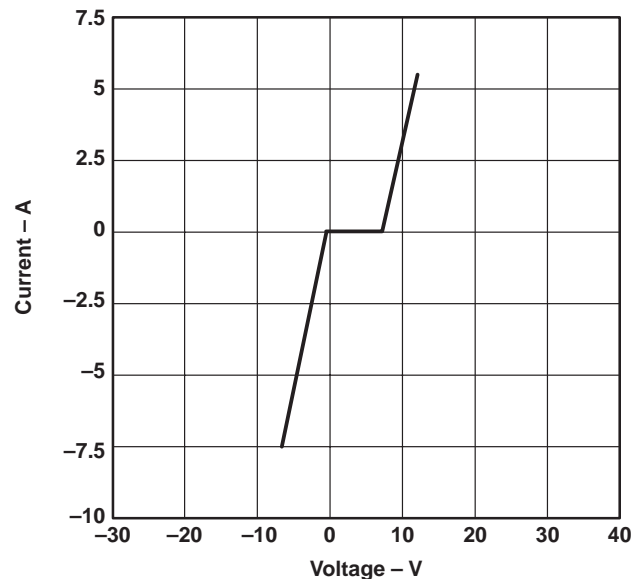

NOTE A: Typical current versus voltage curve was derived using the IEC 1.2/50- μ s surge waveform.

PRODUCTION DATA information is current as of publication date. Products conform to specifications per the terms of Texas Instruments standard warranty. Production processing does not necessarily include testing of all parameters.



POST OFFICE BOX 655303 • DALLAS, TEXAS 75265

Copyright © 1998, Texas Instruments Incorporated

SN75240 DUAL UNIVERSAL SERIAL BUS PORT TRANSIENT SUPPRESSOR

SLLS266A – FEBRUARY 1997 – REVISED MAY 1998

absolute maximum ratings over operating free-air temperature range (unless otherwise noted)†

Continuous total power dissipation	See Dissipation Rating Table
Electrostatic discharge	Class 3, A:15 kV, B: 2 kV
Peak power dissipation, $P_{D(peak)}$	60 W
Peak forward surge current, I_{FSM}	3 A
Peak reverse surge current, I_{RSM}	-9 A
Storage temperature range, T_{stg}	-65°C to 150°C
Lead temperature 1,6 mm (1/16 inch) from case for 10 seconds	260°C

† Stresses beyond those listed under “absolute maximum ratings” may cause permanent damage to the device. These are stress ratings only, and functional operation of the device at these or any other conditions beyond those indicated under “recommended operating conditions” is not implied. Exposure to absolute-maximum-rated conditions for extended periods may affect device reliability.

DISSIPATION RATING TABLE

PACKAGE	$T_A \leq 25^\circ\text{C}$ POWER RATING	DERATING FACTOR ABOVE $T_A = 25^\circ\text{C}$	$T_A = 70^\circ\text{C}$ POWER RATING	$T_A = 85^\circ\text{C}$ POWER RATING
P	1150 mW	9.2 mW/°C	736 mW	598 mW
PW	520 mW	4.2 mW/°C	331 mW	268 mW

‡ This is the inverse of the junction-to-ambient thermal resistance when board-mounted and with no air flow.

recommended operating conditions

	MIN	MAX	UNIT
Operating free-air temperature, T_A	0	70	°C

electrical characteristics over recommended operating conditions (unless otherwise noted)

PARAMETER	TEST CONDITIONS	MIN	TYP	MAX	UNIT
I_{lkg} Leakage current	$V_I = 6\text{ V}$ at A, B, C, or D terminals			1	μA
$V_{(BR)}$ Breakdown voltage	$V_I = 1\text{ mA}$ at A, B, C, or D terminals		7		V

APPLICATION INFORMATION

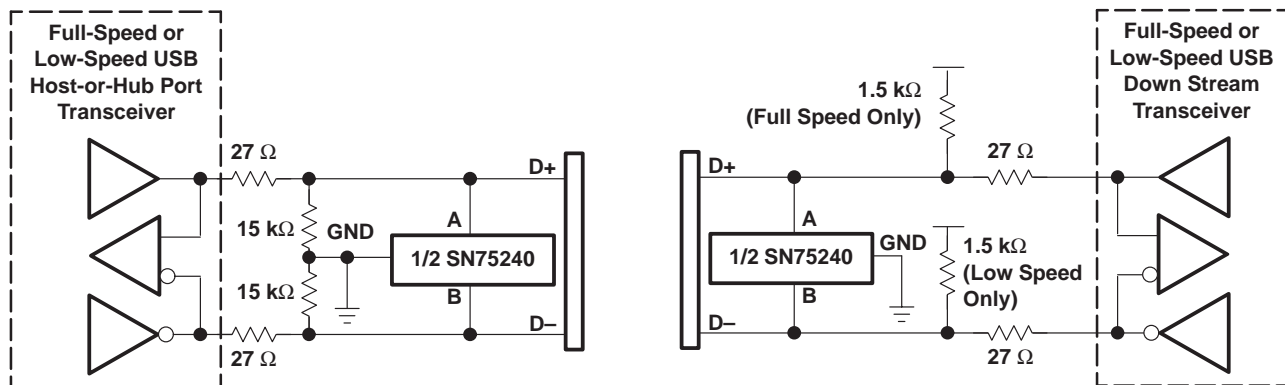

Figure 1. Typical USB Application

SN75240
DUAL UNIVERSAL SERIAL BUS PORT
TRANSIENT SUPPRESSOR

SLLS266A – FEBRUARY 1997 – REVISED MAY 1998

MECHANICAL INFORMATION

P (R-PDIP-T8)

PLASTIC DUAL-IN-LINE PACKAGE

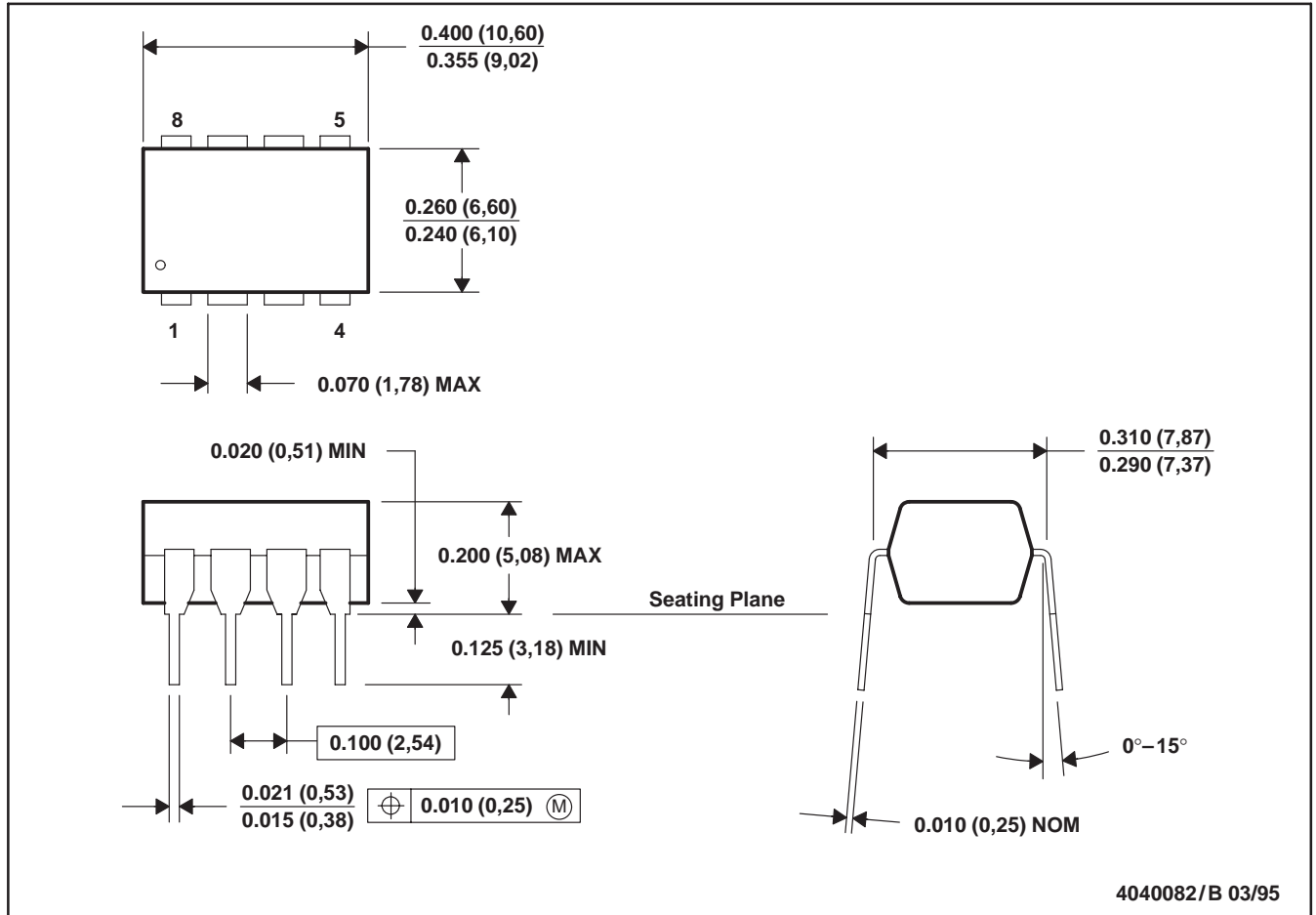

- NOTES: A. All linear dimensions are in inches (millimeters).
 B. This drawing is subject to change without notice.
 C. Falls within JEDEC MS-001

SN75240
DUAL UNIVERSAL SERIAL BUS PORT
TRANSIENT SUPPRESSOR

SLLS266A – FEBRUARY 1997 – REVISED MAY 1998

MECHANICAL INFORMATION

PW (R-PDSO-G)**

PLASTIC SMALL-OUTLINE PACKAGE

14 PIN SHOWN

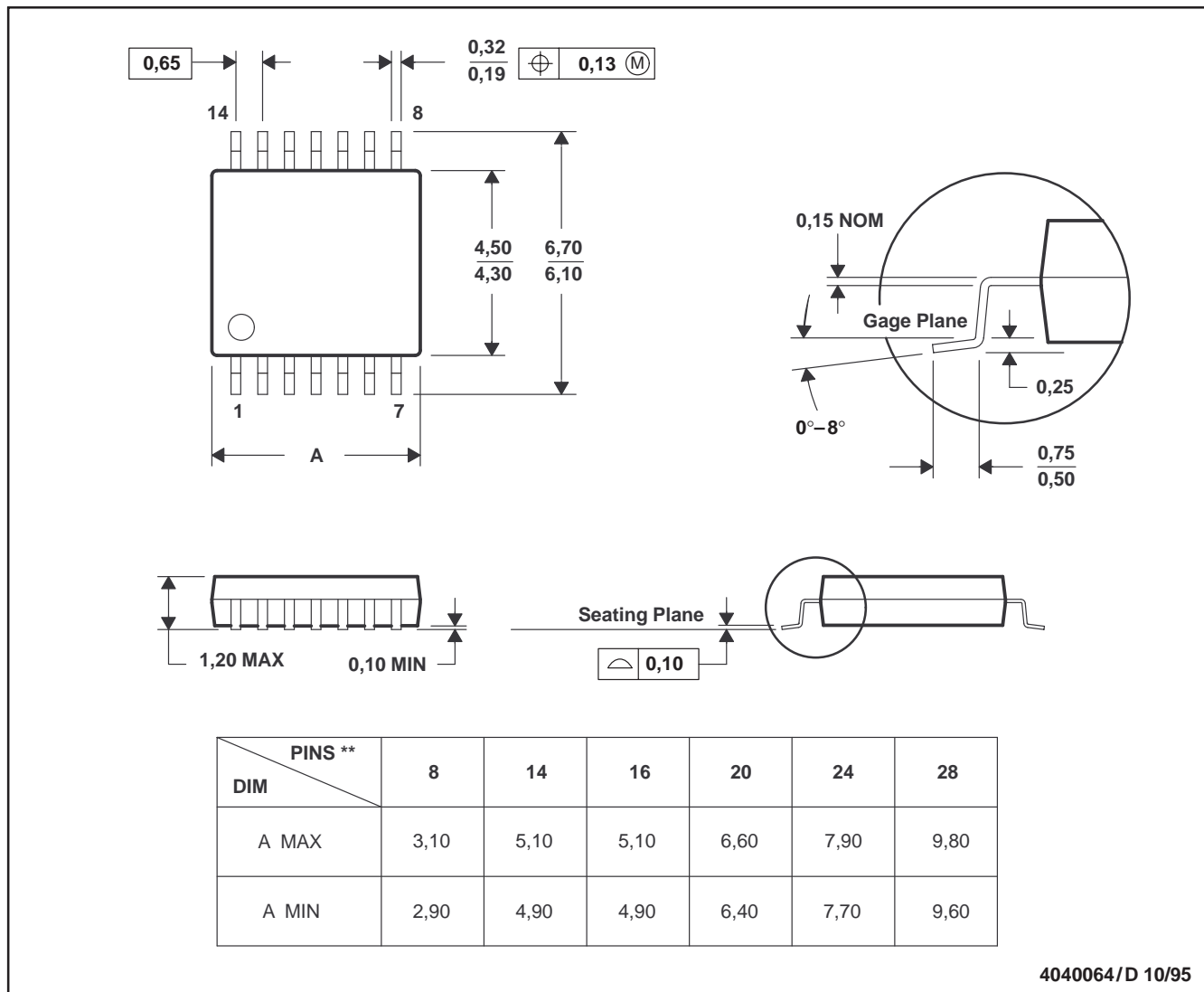

4040064/D 10/95

- NOTES: A. All linear dimensions are in millimeters.
 B. This drawing is subject to change without notice.
 C. Body dimensions do not include mold flash or protrusion not to exceed 0,15.
 D. Falls within JEDEC MO-153

IMPORTANT NOTICE

Texas Instruments and its subsidiaries (TI) reserve the right to make changes to their products or to discontinue any product or service without notice, and advise customers to obtain the latest version of relevant information to verify, before placing orders, that information being relied on is current and complete. All products are sold subject to the terms and conditions of sale supplied at the time of order acknowledgement, including those pertaining to warranty, patent infringement, and limitation of liability.

TI warrants performance of its semiconductor products to the specifications applicable at the time of sale in accordance with TI's standard warranty. Testing and other quality control techniques are utilized to the extent TI deems necessary to support this warranty. Specific testing of all parameters of each device is not necessarily performed, except those mandated by government requirements.

CERTAIN APPLICATIONS USING SEMICONDUCTOR PRODUCTS MAY INVOLVE POTENTIAL RISKS OF DEATH, PERSONAL INJURY, OR SEVERE PROPERTY OR ENVIRONMENTAL DAMAGE ("CRITICAL APPLICATIONS"). TI SEMICONDUCTOR PRODUCTS ARE NOT DESIGNED, AUTHORIZED, OR WARRANTED TO BE SUITABLE FOR USE IN LIFE-SUPPORT DEVICES OR SYSTEMS OR OTHER CRITICAL APPLICATIONS. INCLUSION OF TI PRODUCTS IN SUCH APPLICATIONS IS UNDERSTOOD TO BE FULLY AT THE CUSTOMER'S RISK.

In order to minimize risks associated with the customer's applications, adequate design and operating safeguards must be provided by the customer to minimize inherent or procedural hazards.

TI assumes no liability for applications assistance or customer product design. TI does not warrant or represent that any license, either express or implied, is granted under any patent right, copyright, mask work right, or other intellectual property right of TI covering or relating to any combination, machine, or process in which such semiconductor products or services might be or are used. TI's publication of information regarding any third party's products or services does not constitute TI's approval, warranty or endorsement thereof.